

Wet Area Waterproofing System

Flexible Sealer Hydrathane Liquid Flash 1



Application



Liquid Flash 2



Application



Substrates

Floors
Concrete,
Cement sheet

Walls
Brick, Block,
Wet area boards,
Cement sheet

Waterproofing Membranes

Flexible Sealer

Water-based, acrylic membrane

Hydrathane

Fast-cure, water-based polyurethane

Liquid Flash 1

Microfibre-reinforced membrane

Liquid Flash 2

Two-pack, fast-cure, acrylic membrane

Substrates

Applied in accordance with the manufacturer's instructions.

Floors - Concrete, approved fibre-reinforced cement sheets.

Walls - Cement render, masonry, concrete, fibre-reinforced cement sheets or wet area boards.

Application Temperature

10° - 30°C

Surface Preparation

Waterproofing must be in accordance with AS3740:2021 and local standards.

Surfaces to be waterproofed must be sound and free of dirt, dust, grease and other contaminants and allowed to dry before priming. The waste hole in compressed cement flooring must be cut no more than 5mm larger than the waste external diameter. Recess drainage flange. New concrete must have cured for 28 days.

Screed

Adjust falls to waste using **Driscreed**, a premixed, polymer-modified screed.

Priming

Apply **Primebond** with a brush to the prepared dry surface. When the surface becomes dry (after approximately 15-20 minutes) apply the membrane - wash up with clean water.

Apply bond breaker tape to joints

Place 50mm bond breaker tape or 13mm bead of neutral cure silicone at the wall/floor/hob/waste junctions and joints in sheeting equally to both surfaces. This will allow for greater movement accommodation, should it occur.

Apply 150mm wide membrane over the bond breaker

Apply a 150mm wide, thick coat of waterproofing membrane centrally over areas where the bond breaker is applied. Reinforce the wet membrane with 140mm **Reomat** to guarantee its thickness and performance.

Apply 1st coat to floor and walls

Apply the 1st coat of membrane to the floor and wall. Take care to seal around the tap and faucet outlets.

Recoat time: Two hours (depending on weather conditions).

Application Temperature: Apply coating in ambient temperatures between 10°-30°C.

Apply 2nd coat to floor and walls

Apply a 2nd coat of membrane to the area to be tiled - recoat time is 2 hours. Apply the second coat of membrane at 90° to all of the previous coat applying a thick coat (1.5mm wet) to ensure final dry thickness of 1.5mm. Clean up the uncured coating with clean water.

Curing

Allow the waterproofing membrane to cure for 3 days. Flood test if required then allow the membrane to dry for 24 hours before tiling. Leave for 7 days before putting into use @ 23°C @ 50% relative humidity, longer in cooler conditions.

Thickness

Check the wet film thickness at 0.5 metre intervals and also at 0.5 metres along the bond breaking tape, with a wet film thickness gauge.

Adhere Tiles

Allow the membrane to cure for 72 hours before fixing tiles with **Kemgrip Floor & Wall** mixed with **Elastacrete** or **Kemflex**, **Gripflex** or **Monoflex**. Tiles must be laid so that adequate fall is towards the floor waste. A cement screed can be used to achieve this.

Grouting

Allow adhesive to cure 24 hours before grouting with **Kemgrout**. A silicone sealant is applied to the surface at the junction of wall/wall, wall/floor and hob/floor, hob/wall in place of the grout.

Safety Precautions

The waterproofing membranes and primers are not harmful or toxic. Splashes on the skin and eyes must be washed away with clean water. Apply products in well ventilated areas.

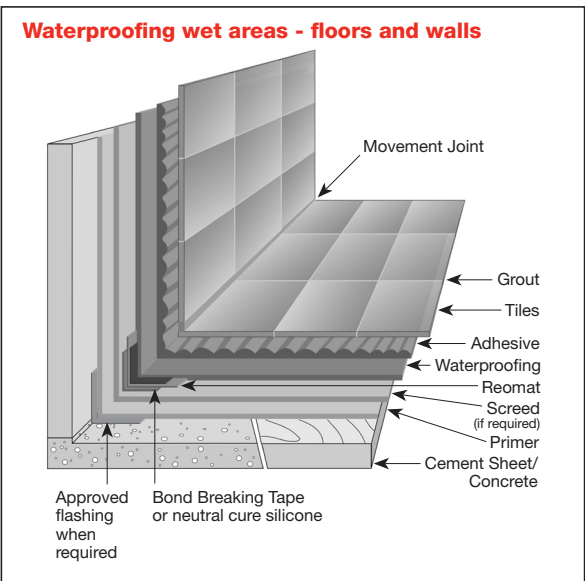
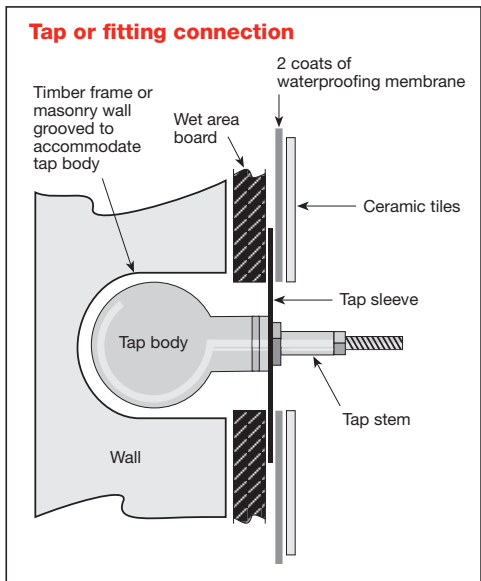
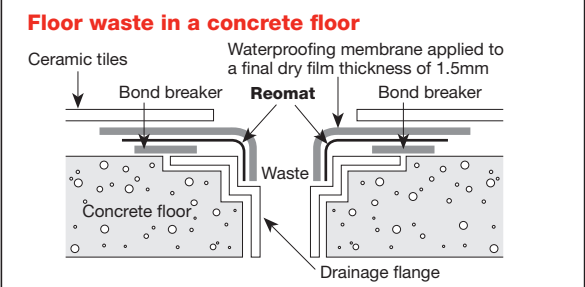
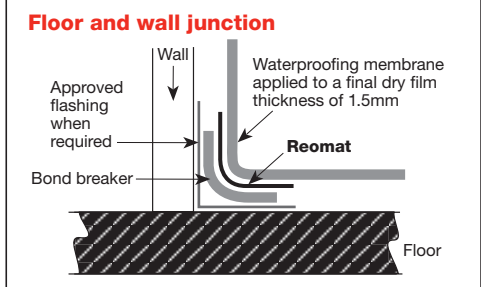
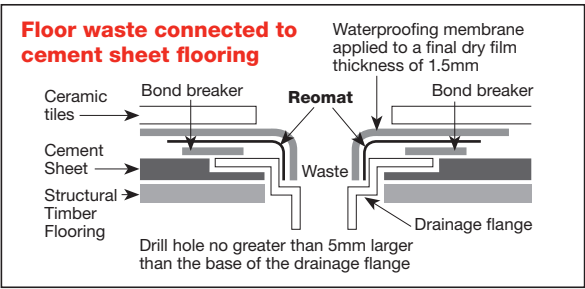
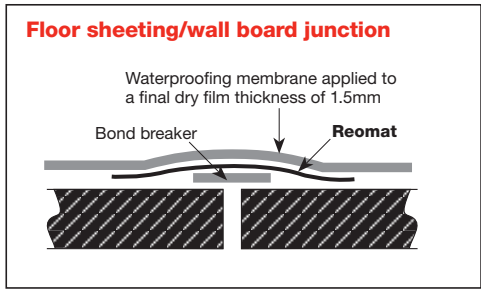

These diagrams are a guide only and should not be considered to be detailed designs. Final designs must be in accordance with AS3740:2021 and any applicable building standards.



Adelaide (08) 8243 7888 **Sydney** (02) 9756 3533
Brisbane (07) 3271 2944 **Auckland** (09) 273 5444
Melbourne (03) 9761 4711 **Kuala Lumpur** (603) 5122 2522
Perth (08) 9356 9999

www.constructionchemicals.com.au